

Attached Lid Containers



Designed to stack together for easy pallet loading.

- Reusable shipping, distribution, order picking, and storage containers.
- Attached lids snap securely closed to protect contents from dust or damage.
- ALC's stack and nest for optimal space use.
- Containers interwork for easy pallet loading.
- Colors: Gray and Blue.

Reinforced hinge pins for years of smooth lid operation

Padlock eye on both ends accommodates security ties

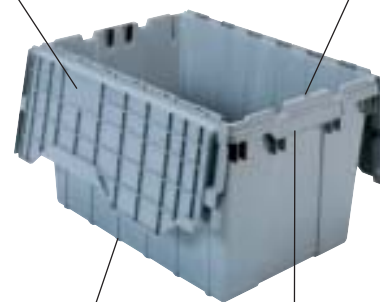

Textured bottoms provide a sure grip on conveyor belts

Strong molded-in handle grips are ergonomically designed for easy lifting and carrying



39085



39120



39170

Akro-ALC's

Model No.	Outside Dimensions Inches			Outside Dimensions mm			Inside Dimension Top Inches			Inside Dimension Top mm			Inside Dimension Bottom Inches		Inside Dimension Bottom mm		Cubic Ft.	Capacity Gal.	Ctn. Qty.
	L	W	H	L	W	H	L	W	H	L	W	H	L	W	L	W			
39085	21½	15	9	546	381	229	19¾	14½	8¾	502	368	219	18⅞	13¼	468	337	1.12	8.5	6
39120	21½	15	12½	546	381	318	19¾	14½	12	502	368	305	18⅞	13¼	468	337	1.62	12	6
39170	21½	15	17	546	381	432	19¾	14½	16⅞	502	368	429	18⅞	13¼	468	337	2.28	17	3

Order in carton quantities.

Akro-ALC's Dolly

Model No.	Dimensions			Ctn. Qty.	Capacity Lbs.	Casters
	L	W	H			
RU843HR1420	19¾"	14⅞"	4¾"	1	900 lbs.	3" Polyolefin

Compatible with Models 39085, 39120, 39170

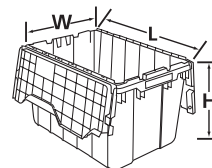

Attached Lid Containers solid steel Dolly (Model No. RU843HR1420) is compatible with Models 39085, 39120, 39170 for efficient parts transport. Also compatible with AR2115 and DL2115 series containers.

Industrial Attached Lid Containers

- Heavy-duty containers for industrial applications.
- Stack and nest design for maximum space usage.
- Injection-molded HDPE construction resists impact, moisture, and most chemicals.
- Tie holes in both ends to provide additional security.
- Containers interwork for easy pallet loading.
- Model AR15141300 is ideal for liquid distribution applications – it holds four, one-gallon jugs or nine 750 ml bottles.

Closed and open style handles available on some models

Reinforced sides and corners for added protection against breakage

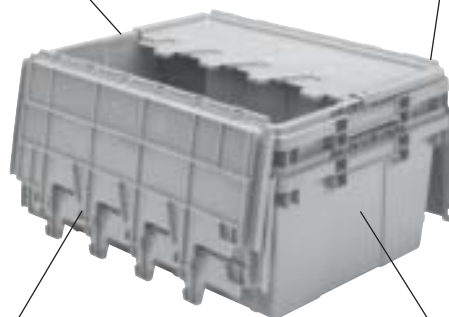

Interlocking fingers on lid provide secure closure and add strength for secure stacking

Textured ID areas on lids and sides for easy application and removal of labels and barcodes

Totes, Bulk Containers & Pallets



Attached lid containers cube pallets and allow better space utilization of trailers and warehouses.



AR15141300



AR20120702



AR21150902



AR21151202



AR21151700



AS22131202



AP22161000



AR24201202



AR27170902



See pages 48-49 for a selection of wood, plastic and steel dollies.



AR27171202



AS28211502



AS34242012

Attached Lid Containers

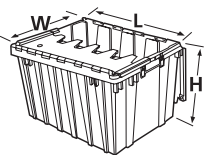

Model No.	Outside Dimensions						Inside Dimensions Bottom						Capacity	
	Inches			mm			Inches			mm			Lbs.	Kg
	L	W	H	L	W	H	L	W	H	L	W	H		
✓AR15141300GY	14 ³ / ₄	13 ¹ / ₂	13 ³ / ₁₆	374	343	338	11 ¹ / ₄	11 ¹ / ₄	11 ¹ / ₈	286	286	302	50	23
✓AR20120702GY	20	11 ¹ / ₁₆	7 ¹ / ₂	510	295	190	16 ¹ / ₈	9 ¹ / ₁₆	6 ¹ / ₁₆	430	245	153	40	18
✓AR21150902GYRB	21 ³ / ₄	15 ¹ / ₄	9 ⁵ / ₁₆	552	387	245	18 ³ / ₈	13	8 ¹ / ₂	467	330	215	60	27
✓AR21151202GYRB	21 ³ / ₄	15 ¹ / ₄	12 ¹³ / ₁₆	552	387	325	17 ⁷ / ₈	12 ¹ / ₂	11 ¹ / ₈	455	320	285	60	27
✓AR21151700GY	21 ³ / ₄	15 ¹ / ₄	17	552	387	431	17 ⁷ / ₁₆	12 ⁷ / ₁₆	15 ¹³ / ₁₆	455	316	404	60	27
✓AS22131202GY	22 ³ / ₈	13	12 ⁷ / ₈	567	330	327	18 ⁵ / ₈	10 ³ / ₃₂	11 ¹ / ₈	483	254	298	60	27
AP22161000GY	21 ³ / ₄	16 ¹ / ₂	10 ¹ / ₄	552	419	260	18 ³ / ₃₂	14	8 ⁵ / ₈	464	356	222	60	27
✓AR24201202GY	24	19 ¹ / ₂	12 ⁵ / ₈	610	495	320	20 ¹ / ₂	16 ¹⁹ / ₃₂	10 ⁵ / ₈	520	421	279	80	36
✓AR27170902GYGR	27 ¹ / ₁₆	16 ⁷ / ₈	9 ⁵ / ₈	687	430	240	23 ⁹ / ₁₀	14 ³ / ₃₂	8	610	360	203	80	36
✓AR27171202GYGR	27 ¹ / ₈	16 ⁷ / ₈	12 ¹ / ₂	689	430	320	23 ¹ / ₂	13 ³ / ₈	10 ⁹ / ₁₀	600	350	278	100	45
✓AS28211502GY	28	20 ³ / ₄	15 ⁷ / ₁₆	710	530	390	25	18	14	635	460	355	100	45
✓AS34242012GY	34	24	19 ⁵ / ₈	865	610	500	29 ⁹ / ₁₀	19 ¹ / ₂	18 ³ / ₃₂	760	495	460	100	45

GY-Grey, GR-Green, R-Red, B-Blue

All stock items are marked with "✓"

Attached Lid Containers Cont.



Dual-purpose attached lid opens out for full access to container when loading.



In flow racks or on shelving, the quarter-half lids open up and back for access through the top of the container.



On the picking or assembly line, the hinged front gate drops down for complete, easy product access.

BinBox™ Container

- Bi-directional attached lid allows easy loading, secure shipping, and quick picking.
- Lid can be secured with ties for extra spillage/theft protection.

Reinforcing ribs on lid add strength for stacking

Nesting stops prevent container jamming

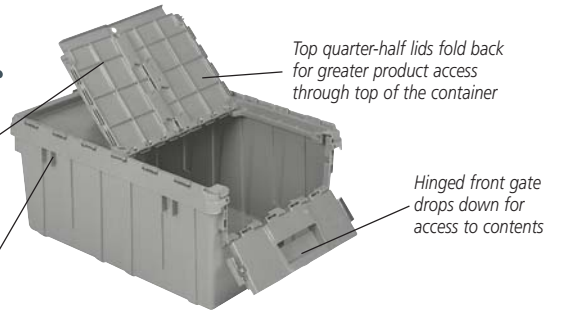

BinBox™ Container

Model No.	Size						Capacity	
	Inches			mm			Lbs.	Kg
	L	W	H	L	W	H		
AB21150900	21¾	15¼	9¼	552	387	235	60	27

Bi-Fold Lid Containers

- Ideal for distribution of small orders – up to .78 cubic feet.
- Interwork with 21" x 15" attached lid containers.
- The attached-recessed lid flaps fold in half and lock against the side of the container for ease of conveying and nesting.
- Interlocking fingers on lid provides secure closure and stacking strength.

Textured areas allow for identification label placement and easy label removal

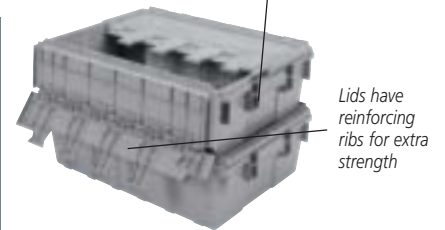

Bi-Fold Lid Containers

Model No.	Size						Capacity	
	Inches			mm			Lbs.	Kg
	L	W	H	L	W	H		
AF21150602	21½	15¼	6¾	546	387	168	60	27



Detached Lid Containers



Handles

Several handle styles available

- Open for easy gripping.
- Closed for increased security.
- Ergonomic for comfortable lifting.
- Handle styles vary by model.

All stock items are marked with "✓"

- Lids are available in recessed style for secure stacking, strapping style for banding use, and high cube for additional storage space.
- Containers stack, nest, and interwork.
- Textured bottom standard on most models to prevent slippage on conveyors. Smooth bottoms also available.
- 24" x 20" containers cube 48" x 40" pallets, 4 per layer.
- Stocked in grey only.

Recessed lid creates a retaining wall to form secure stacks



Detached Lid Containers

Model No.	Size						Capacity	
	Inches			mm			Lbs.	Kg
	L	W	H	L	W	H		
21" x 15"								
✓DL21150512	21¾	15¼	5¾	543	387	170	50	23
✓DL21150712	21¾	15¼	7¾	543	387	200	50	23
✓DL21150900	21¾	15¼	9¾	543	387	243	60	27
✓DL21151202	21¾	15¼	12¾	543	387	314	-	-
24" x 20"								
✓DL24200614	24	20	6¾	610	508	171	50	23
✓DL24201014	24	20	10¾	610	508	264	80	36
✓DL24201202	24	20	12¾	610	508	314	80	36

21" x 15" Detached Lids

Model No.	Description	Dimensions		
		L"	W"	H"
✓DR21150100	Recessed Lid mm/kg	21¾	15¼	1¼
		543	384	30

24" x 20" Detached Lids

Model No.	Description	Dimensions		
		L"	W"	H"
✓DR24200100	Recessed Lid mm/kg	24	20	1¼
		610	508	29